

MOUNTING INSTRUCTION FOR HIGH SECURITY ELECTRIC MORTICE LOCKS  
**Maxima Art. 25500 - 25511**

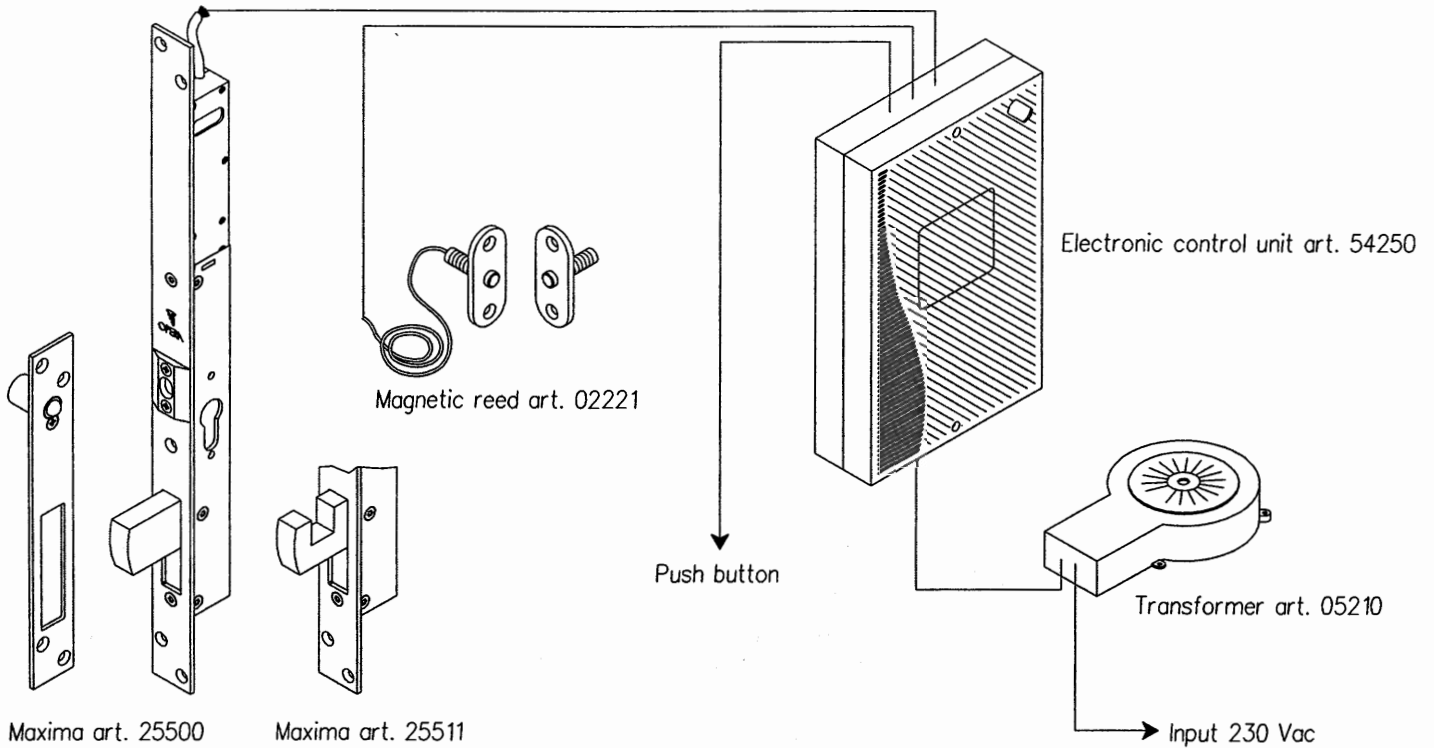

**TECHNICAL DATA**

ITEM	BACKSET mm.	OPERATING VOLTAGE Vdc	POWER INSTANTANEOUS	ELECTRIC LOCK OPERATION TIME	MAXIMUM ELECTRIC LOCK OPERATIONS
25500 - 25511	20-25-30-35-50	9 - 16 TYP 12	50 VA	0.15 sec	15 CICLI/min.

**APPLICATIONS**

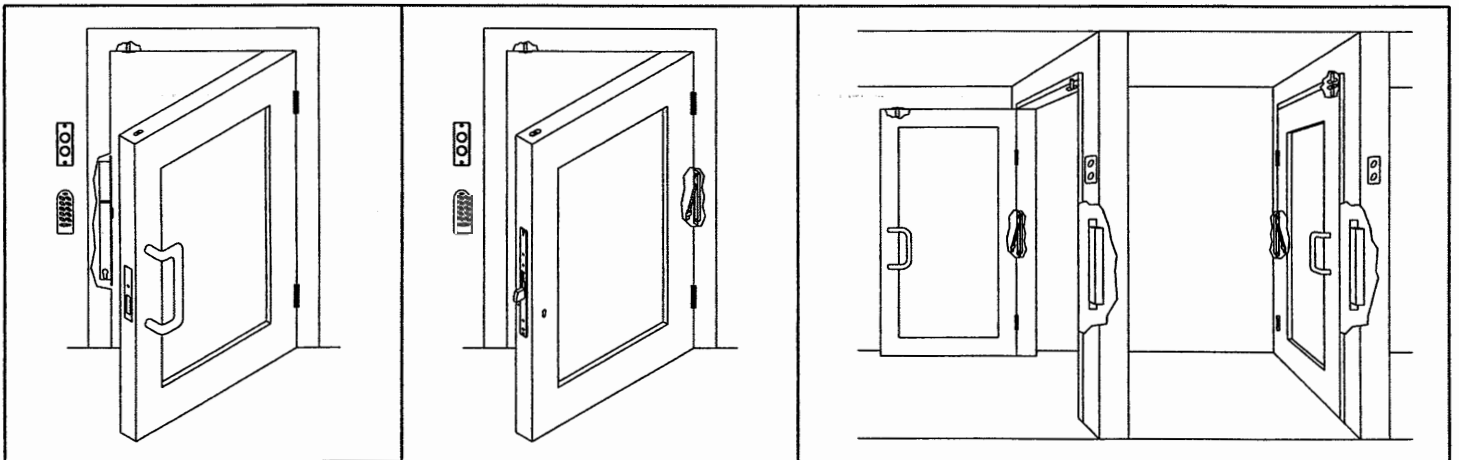

Mounting on security door controlled by a keypad.  
Motor locked installed on the frame.  
Mechanical override trough  
Euro-profile cylinder.

Mounting on security door controlled by a keypad.  
Motor locked installed on the door.  
Mechanical override trough  
Euro-profile cylinder.

Mounting on a two doors interlocking system.

# DIMENSIONS

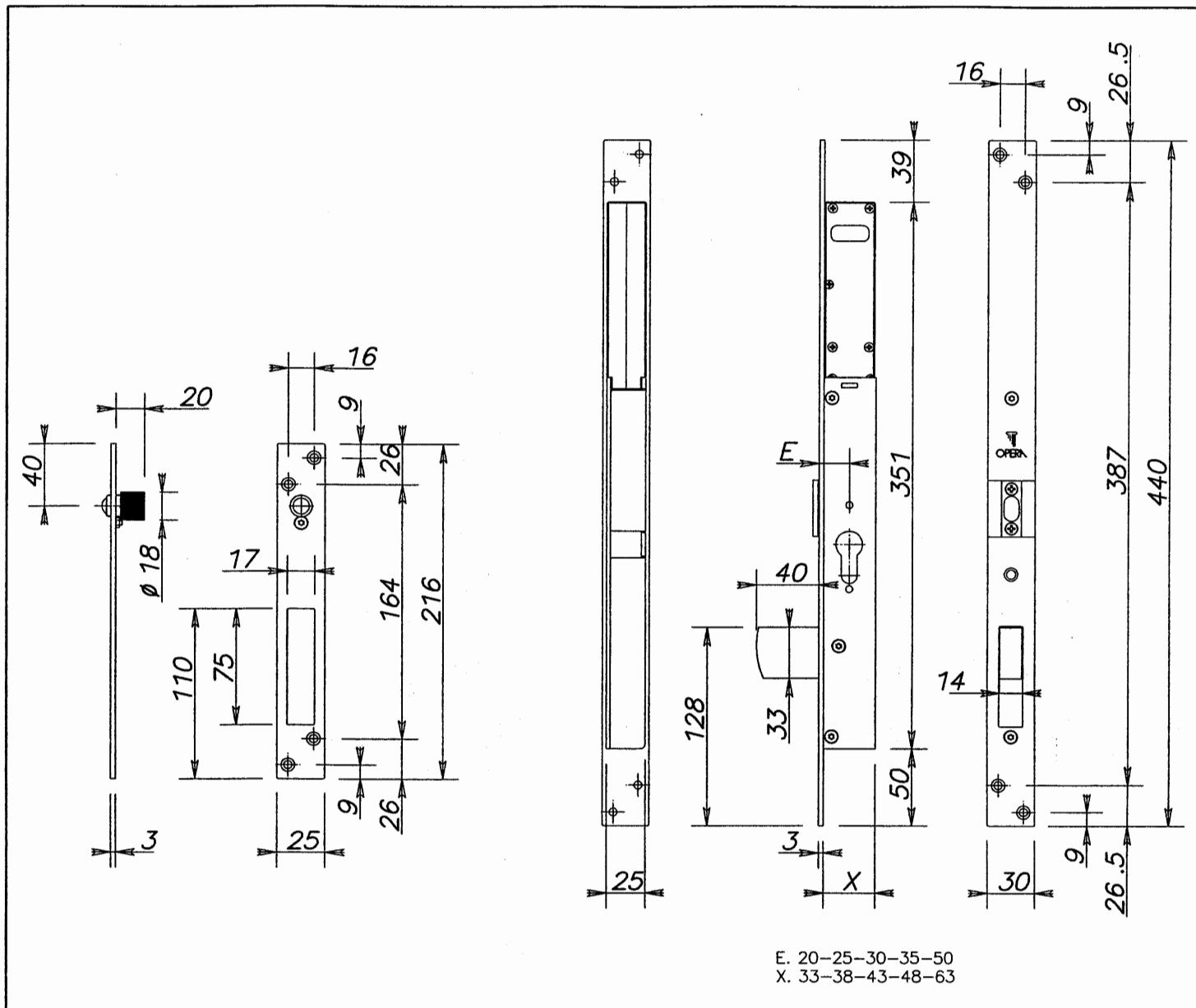

# MECHANICAL MOUNTING

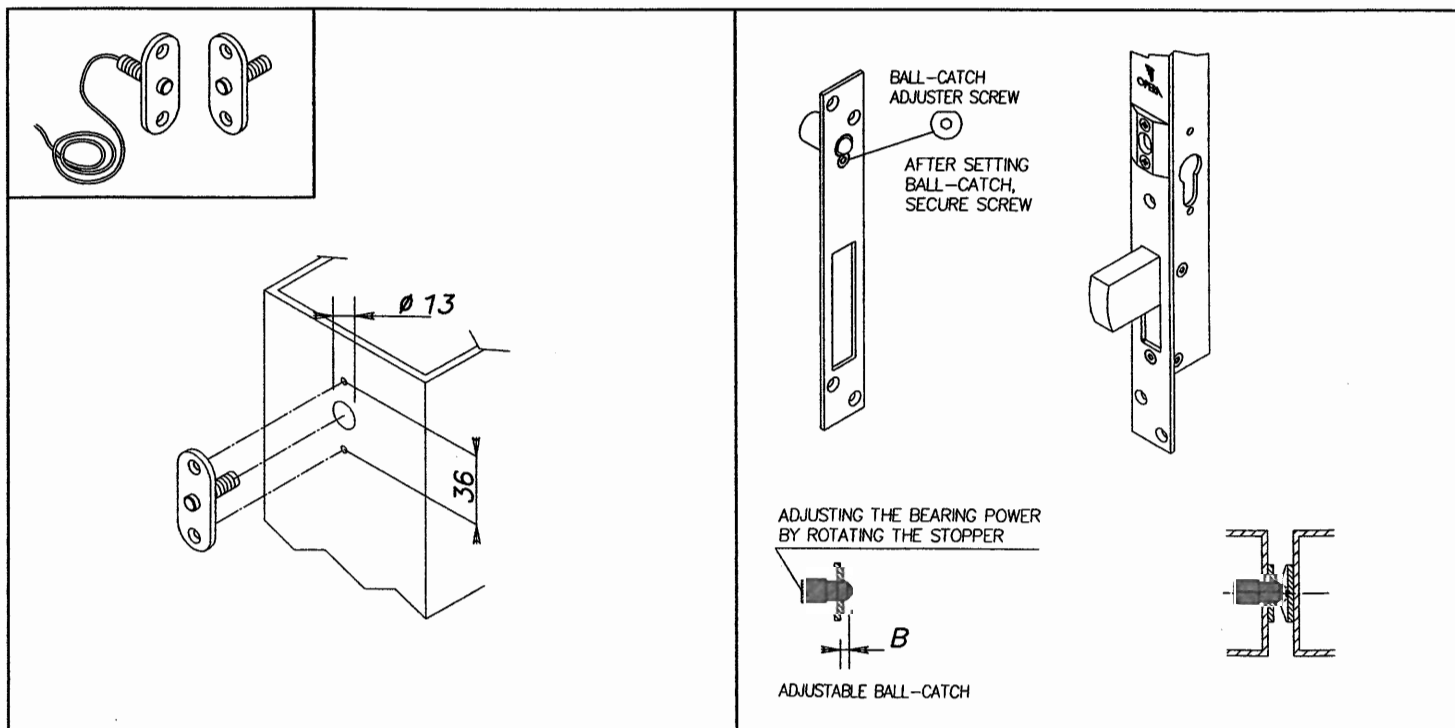

# ELECTRICAL DIAGRAM FOR CONNECTING MOTORIZED LOCK TO THE CONTROL UNIT

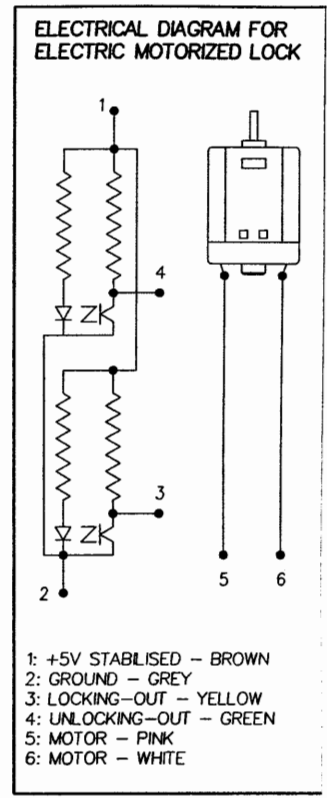
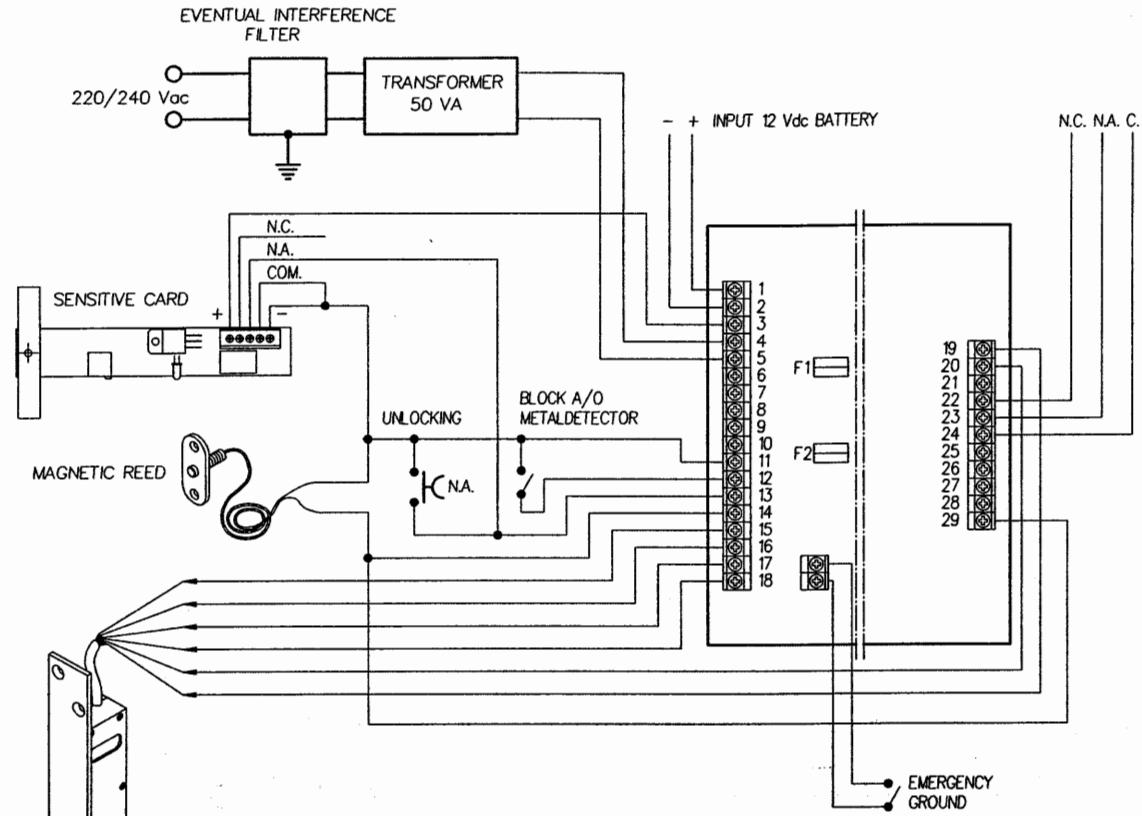

- 1: +5V STABILISED - BROWN
- 2: GROUND - GREY
- 3: LOCKING-OUT - YELLOW
- 4: UNLOCKING-OUT - GREEN
- 5: MOTOR - PINK
- 6: MOTOR - WHITE

- |    |   |                               |
|----|---|-------------------------------|
| 1  | + INPUT BATTERY 12Vdc                                     |                               |
| 2  | - BATTERY 12 Vdc  |                               |
| 3  | VOLTAGE FOR SENSITIVE CARD - 12 Vdc/500mA MAX             |                               |
| 4  | INPUT 10 Vac  |                               |
| 5  |   |                               |
| 6  | ENTRY   | ] ONLY FOR INTERLOCKING DOORS |
| 7  | ENTRY   |                               |
| 8  | ENTRY   |                               |
| 9  | EXIT  |                               |
| 10 | GROUND  |                               |
| 11 | GROUND  |                               |
| 12 | INIBIT LOCK A/O METAL DETECTOR                            |                               |
| 13 | LOCK OPENER   |                               |
| 14 | LOCK CLOSER   |                               |
| 15 | GREY  | ] <u>CABLE LOCK</u>           |
| 16 | YELLOW  |                               |
| 17 | GREEN   |                               |
| 18 | BROWN   |                               |
| 19 | PINK  |                               |
| 20 | WHITE   |                               |
| 21 | GROUND  |                               |
| 22 | CONTACT N.C.  | ] RELE' 1                     |
| 23 | CONTACT N.A.  |                               |
| 24 | COMMON  |                               |
| 25 | CONTACT N.C.  | ] RELE' 2                     |
| 26 | CONTACT N.A.  |                               |
| 27 | COMMON  |                               |
| 28 | LOCK'S FAULT (OUTGOING WITH OPEN COLLECTOR 30V 150mA MAX) |                               |
| 29 | MAGNETIC REED   |                               |
- F1 FUSE OF PROTECTION FOR BATTERY  
 - F2 FUSE FOR ALTERNATING CURRENT  
 - THE TERMINAL 1 AND 2 DON'T CHERGE THE BATTERY
- IMPORTANT:**  
 DO NOT USE PRESSURE CONTACTS BETWEEN HEAD DOOR AND THE DOOR TO CONNECT THE LOCK AND THE SENSITIVE CARD.

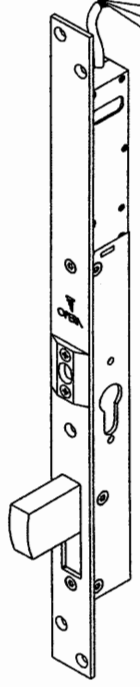

**TECHNICAL NOTICE FOR A PROPER INSTALLATION**

To make a proper installation of the motor lock, ensure that the electronic unit is located near the lock – see following chart for right distance and wires.

Do not pass 3 Mt. distances for connection between Electronic unit and transformer or power supply.

To avoid electrical disturbs, the connections cables must be posed in dedicated tracks. Do not pose them with other cables belonging to different applications.

<b>Minimum</b> wires section – Cables RED and WHITE for connection between electronic unit and lock’s motor. mm.	<b>Maximum</b> wires section – Cables RED and WHITE for connection between electronic unit and lock’s motor. Mt.
0,33	3
0,50	From 3 to 10
1,50	From 10 to 30
2,50	From 30 to 50

All others connections can be done with wires diameter 0,33mm

Use larger sections in case of bigger distance

Do not use telephone wires.

In case of use with a transformer, verify tension is not passing the 10Vac. Bigger tension can short the motor life. This passage must be done only in case the motor is replacing an existing one.

Do not use magnetic contacts between frame and doors. Lead covers must protect the wires between frame and door.

# ELECTRICAL CONNECTIONS TO EFFECT INTERLOCKING DOORS.

SYMPLE INTERLOCK SYSTEM

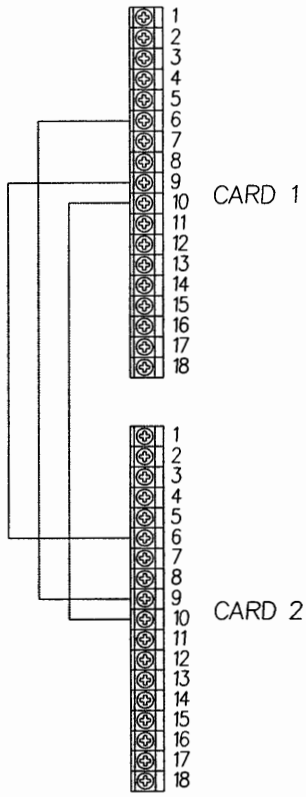

SYSTEM 3 INTERLOCKING DOORS

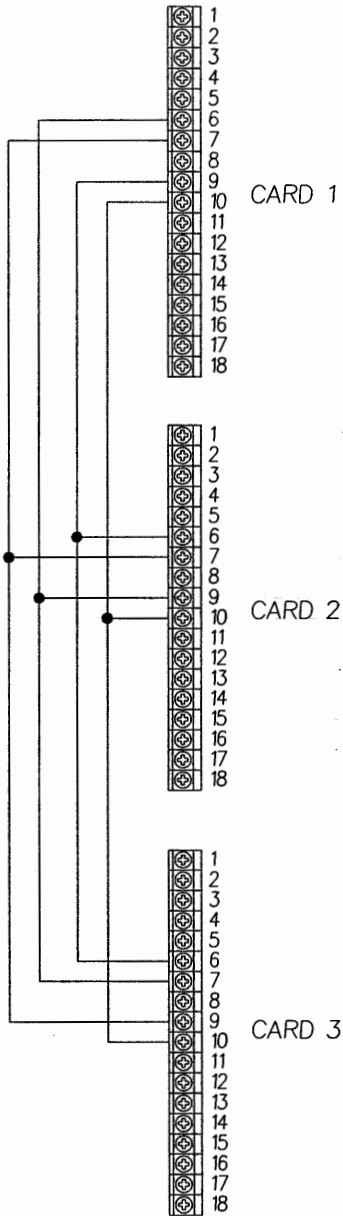

SYSTEM 4 INTERLOCKING DOORS

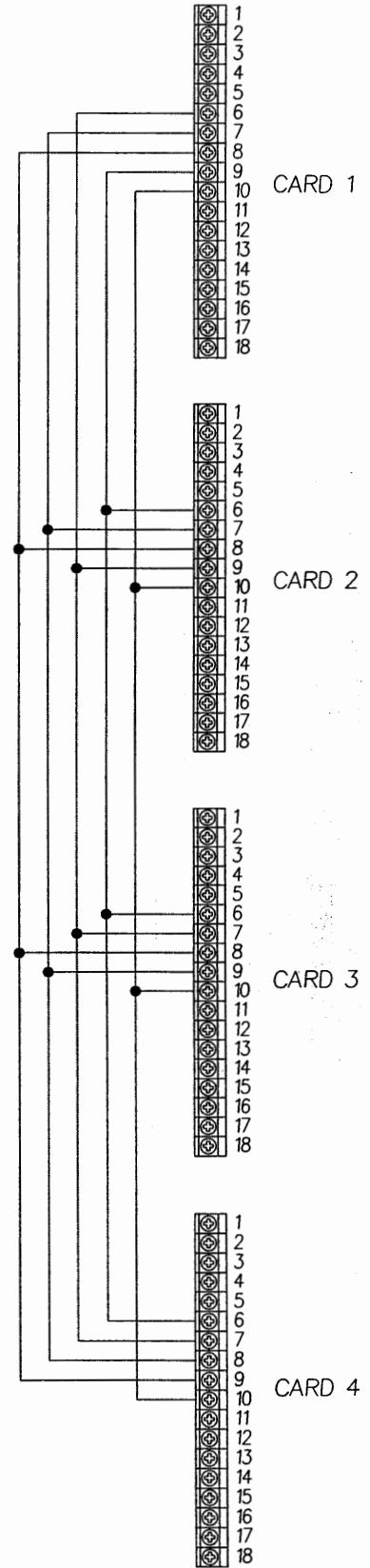
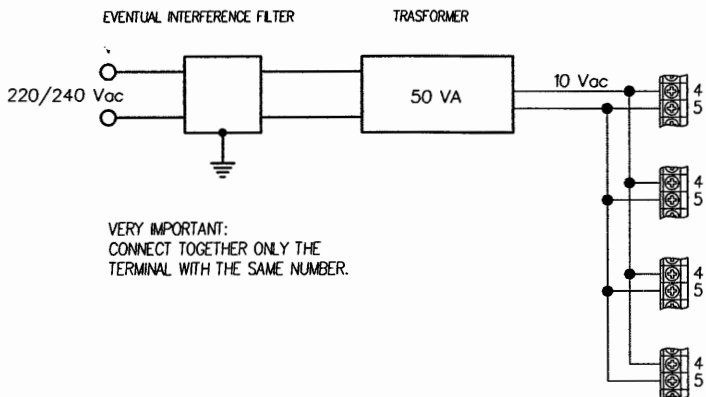

DIAGRAM OF CONNECTION FOR CARDS FEEDING



THE NOT MENTIONED CONNECTIONS INTO THE SCHEME OF THE PAGE HAVE TO BE CONSIDERED AS SINGLE CARD.